



# **2.0 VERTICALE**

**10 - 12 DC Inverter**

We would first of all like to thank you for having chosen one of our products.

We are sure you will be happy with it because it represents the state of the art in the technology of home air conditioning.

By following the suggestions contained in this manual, the product you have purchased will operate without problems, giving you optimum room temperatures with minimum energy costs.

Innova S.r.l

## Compliance

This unit complies with the following European Directives:

- Low voltage 2014/35/EU
- Electro-magnetic compatibility 2014/30/EU
- Use restrictions of hazardous substances in electrical and electronic equipment 2011/65/EC (RoHS2)
- Waste electrical and electronic equipment 2012/19/EC (WEEE).

- Energy consumption indication on the labels of energy-related products 2010/30/EU
- ErP Directive 2009/125/EC and regulation 2012/20EC

 For declarations of conformity, certificates and other certification details please consult the website.

## Symbols

The pictograms in the next chapter provide the necessary information for correct, safe use of the appliance in a rapid,

unmistakable way.

## Editorial pictograms

 **U** User  
- Refers to pages containing instructions or information for the user.

 **I** Installer  
- Refers to pages containing instructions or information for the installer.

 **S** Service  
- Refers to pages containing instructions or information for the CUSTOMER TECHNICAL ASSISTANCE SERVICE.

## Safety pictograms

 **Warning**  
- It indicates actions that require caution and a suitable preparation.

 **Prohibition**  
- Refers to prohibited actions.

<b>1</b>	<b>General</b>	
1	General warnings . . . . .	4
2	Fundamental safety rules . . . . .	4
3	Description . . . . .	5
4	Storage . . . . .	5
5	Handling . . . . .	6
6	Shipping dimensions and weight . . . . .	6
7	Supplied components . . . . .	6
8	Unit parts . . . . .	7
<b>2</b>	<b>Installation</b>	
1	Installation method . . . . .	8
2	Placement of the unit . . . . .	8
3	Assembling the unit . . . . .	9
4	Condensation drain preparation . . . . .	10
5	Removing the compressor block . . . . .	11
6	Assembling air ducts and external shutters . . . . .	12
7	Mounting the appliance on the bracket . . . . .	13
8	Electrical connection . . . . .	13
9	Setting cool only or heat only modes . . . . .	14
10	Brightness regulation . . . . .	14
11	Touch-screen display key lock . . . . .	14
12	Hotel function . . . . .	14
13	Detecting possible faults . . . . .	15
<b>3</b>	<b>Troubleshooting</b>	
1	Periodic Maintenance . . . . .	17
2	Troubleshooting . . . . .	18
3	Technical specifications . . . . .	19

This booklet, code N420036A - Rev. 06 - (11/20) consists of 20 pages.

# GENERAL

## 1.1 General warnings

- ⚠ After unpacking, check that the contents are intact and that all parts are included. If not, contact the agent who sold the appliance to you.
- ⚠ The appliance must be installed by an authorised company. Once the work is done, it must issue a declaration of conformity to the client in compliance with current regulations and with the indications in the instruction manual supplied by the manufacturer with the appliance.
- ⚠ These appliances have been designed for conditioning and/or heating rooms and they must be destined solely for this purpose, in accordance with their performance characteristics.  
The manufacturer refuses any contractual or extra-contractual liability for damage caused to people, animals or property resulting from incorrect installation, adjustment, maintenance or improper use.
- ⚠ In the event of water leaks, turn off the main switch and close the water taps.  
Immediately call the Technical Assistance Service or other qualified personnel and do not intervene personally on the appliance.
- ⚠ A temperature that is too high or too low is harmful to health and is an unnecessary waste of energy.  
Avoid prolonged direct contact with the air flow.
- ⚠ Do not leave the room closed for long. Periodically open the windows to ensure proper ventilation.
- ⚠ This instruction booklet is an integral part of the appliance and, therefore, it must be kept with care and must ALWAYS accompany the appliance, even when the latter is transferred to another owner or user or transferred to another system. If it gets damaged or lost, please request another copy from the local Technical Assistance Service.
- ⚠ Repairs or maintenance must be performed by the Technical Assistance Service or by qualified personnel in accordance with this manual. Do not modify or tamper with the appliance as this could create dangerous situations and the manufacturer will not be liable for any damage caused.
- ⚠ When replacing components, use only original spare parts.
- ⚠ The appliance is declared to have an IPX0 protection rating, therefore, it cannot be installed outdoors or in laundry rooms.

## 1.2 Fundamental safety rules

- ⊖ The use of products that use electricity and water requires the observation of some fundamental safety rules such as:
  - ⊖ The unit can be used by children over the age of 8, and by people with reduced physical, sensory or mental capabilities, or with no experience or necessary knowledge, as long as they are monitored or after they have received instructions on the safe use of the unit and have understood the dangers involved.  
Children must not play with the appliance.  
The cleaning and maintenance that must be performed by the user should not be carried out by children without supervision.
  - ⊖ It is forbidden to modify the safety or adjustment devices without authorisation from and indications of the manufacturer.
  - ⊖ It is forbidden to pull, remove or twist the electric cables coming out of the unit, even when disconnected from the mains power supply.
  - ⊖ It is forbidden to introduce objects or substances through the aspiration grills and the air outflow.
  - ⊖ It is forbidden to open the access doors to the internal parts of the appliance without having turned off the main switch first.
  - ⊖ It is forbidden to dispose of, or leave in the reach of children, the packaging materials which could become a source of danger.
  - ⊖ It is forbidden to climb onto the appliance and/or to place any type of object on top of it.

### 1.3 Description

The air conditioning unit "2.0" is the new solution that represents a significant step towards reducing the aesthetic impact of air conditioners. With a depth of just 16 centimetres, "2.0" is the most compact and least bulky of the category. Its aesthetic impact is therefore minimal, both inside and out.

#### Optimised Capacities

The conditioning capacities of "2.0" have been optimised so as to obtain the right temperature for the best level of comfort and, therefore, less consumption and less noise. Thanks to the careful choice of sound insulation materials, the noise is similar to that of a standard wall split unit and consumption is drastically contained thanks to the new direct current fan.

#### 162 millimetre holes

An important choice not only for the design, but also for a significant installation advantage: easier to find drilling tools, no need for professional drills, even less aesthetic impact.

#### BLDC inverter technology

We have perfected the inverter technology to offer the best in terms of acoustic comfort (noise) and performance: reduction of consumptions, maintenance of the best temperature level and humidity level in the room.

Thanks to the use of the cutting edge BLDC (brushless direct current) inverter regulation, vibrations have been completely eliminated and acoustic emissions have been lowered to exceptional levels.

Both ventilation motors are BLDC to reduce consumption still further and make flow adjustment more precise.

The energy consumption is extremely low thanks to absorption values falling below 300 W in the case of partial

load. At the nominal cooling power of 2.35 kW "2.0" has an EER equal to 3.24 (10 HP) and 3.22 (12 HP) which allows an energy efficiency ratio of "A+" to be obtained, this is the cutting edge in the sector of monobloc climate control systems with fixed installation.

#### Easy to install

"2.0" can be installed on any perimeter wall either low or high. Everything needed for installation (template, support bracket, hole pipes and external grids), excluding the drill and drill bit, is included in the box.

#### Folding external grids

"2.0" is equipped with folding grids activated by inlet and outlet air. They open when the unit is working and close when it's turned off. Better indoor comfort, less dust, noise and pollution, less maintenance and even less outdoor visibility.

#### Remote control and on-board touch-screen display

In addition to the remote control, the touch-screen display on the unit enables the setting of any function. There's even a "lock" mode to avoid any improper use. With a simple action on the touch screen display, the "heating" function can be deactivated: the appliance will then operate in "cooling" only, without the need for the condensate discharge pipe. The orientation of the air flaps, upwards or downwards, can also be set by simply pressing a key.

### 1.4 Storage

The packing is made of suitable material and carried out by expert personnel. All units are checked and tested and are delivered complete and in perfect conditions, however please perform the following instructions to check the quality of shipping services:

- upon receipt, check if the box is damaged. If that is the case, accept the goods with reservations and keep photographic evidence of any damage found
- unpack and check the contents against the packing list.
- check that none of the parts have been damaged during shipment. In case of damage, report it to the shipping company within 3 days of receipt by

Store the box in a closed environment protected from atmospheric agents and isolate it from the floor using planks or pallets.

registered letter with return receipt and attaching photographic documentation. A copy should also be sent by fax to the MANUFACTURER. No notice of damage incurred will be accepted after 3 days from delivery.

- ⚠ Keep the packing at least for the duration of the warranty period, in case you need to ship the air-conditioner to the service centre for repair. Dispose of the packing materials in compliance with current regulations on waste disposal.

- ⚠ Do not turn the carton upside down

### 1.5 Handling

The unit is packed singularly in a cardboard box. Boxes can either be carried singularly by hand by two operators or loaded on a transport cart..

⚠ Handling must be performed by qualified personnel, with specific tools and with equipment suitable for the weight of the appliance.

⚠ The appliance is unbalanced on the right (compressor side)

⚠ During transportation, the appliance must be kept in vertical position.

### 1.6 Shipping dimensions and weight

Packaging	M.E.	2.0 10 HP and 12 HP
<b>Dimensions</b>		
Weight	kg	62
W	mm	580
H	mm	1547
D	mm	265

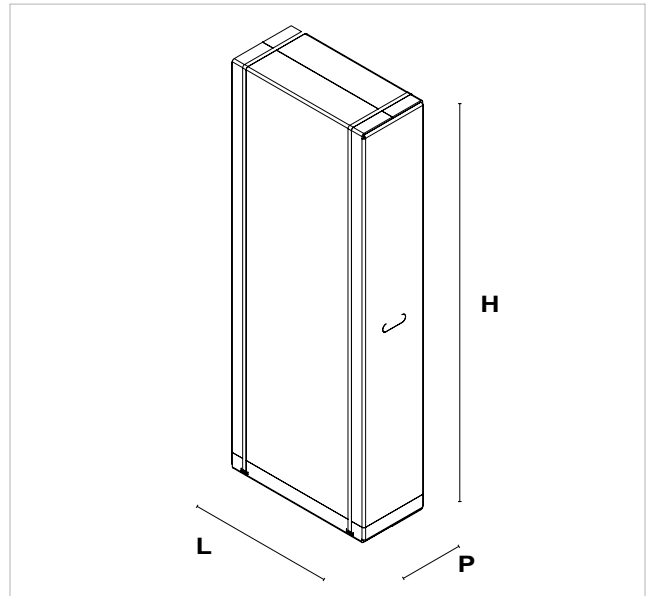

### 1.7 Supplied components

The supply consists of the parts listed in the following table. Before assembly, please check that they are all at hand.

<b>A</b>	External fixed grid for air inlet and outlet (front view)
<b>B</b>	Screws and plugs kit (6 pcs)
<b>C</b>	Bracket for wall mounting
<b>D</b>	User manual
<b>E</b>	Remote control
<b>F</b>	Paper template for holes.

<b>G</b>	CR2025 3V remote control battery
<b>H</b>	Wall inlet pipes (2 pcs)
<b>I</b>	Energy efficiency label
<b>N</b>	Installation manual
<b>O</b>	External fixed grid for air inlet and outlet (rear view)

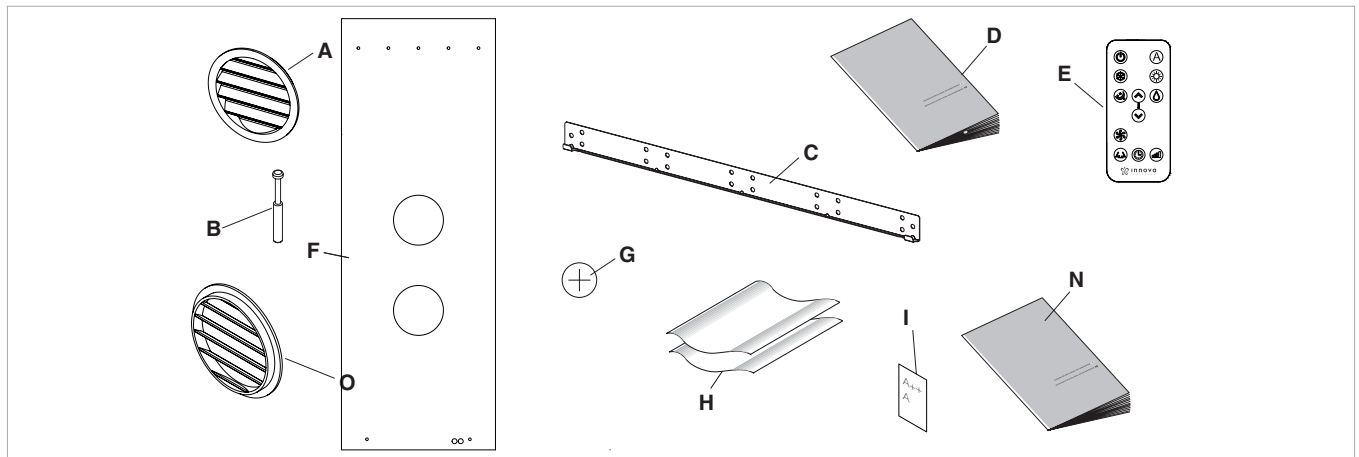

**1.8 Unit parts**

<b>1</b>	Internal air intake grill
<b>2</b>	Touch screen display
<b>3</b>	Front panel
<b>4</b>	Outdoor air outlet
<b>5</b>	Outdoor air suction
<b>6</b>	Air outlet grill

<b>7</b>	Air Filter
<b>8</b>	Condensation drain pipe
<b>9</b>	Room air probe
<b>10</b>	Power supply terminal block
<b>11</b>	Decorative side panel
<b>12</b>	Anti-lifting bracket

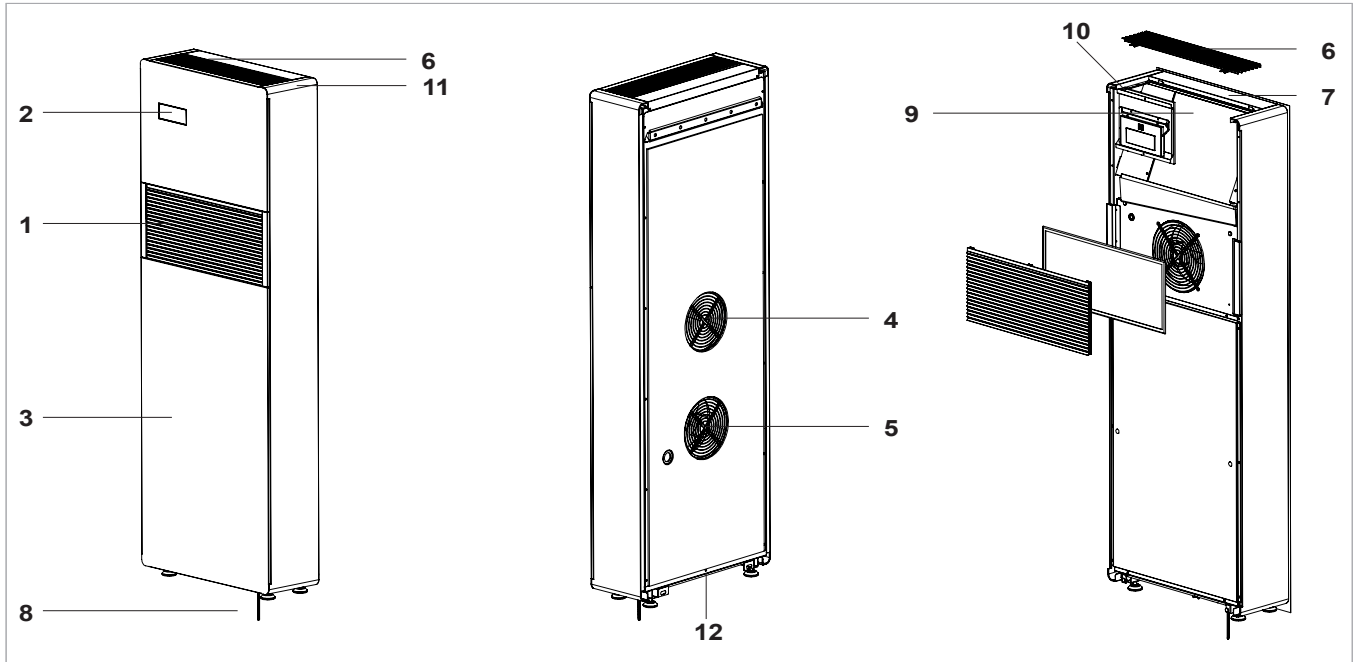

EN

## INSTALLATION

### 2.1 Installation method

Before installing the conditioner, it is essential to calculate the summer thermal loads (and winter ones for the models with a heat pump) of the room. The more exact the calculation, the better the product will work. Please refer to current regulations to carry out calculations. For large-scale installations, please call a specialised heat engineer firm. Therefore, try to reduce higher heat loads by following instructions below:

- Cover large windows exposed to sunlight with curtains or with external maskings (blinds, porches, reflecting films, etc.).
- The room must remain closed for as long as possible.
- Avoid turning on halogen lamps or other high energy consumption appliances such as small ovens, steam irons, hot plates etc.).

### 2.2 Placement of the unit

For the best performance of the appliance and to avoid malfunctions or dangerous situations, the location of the unit must meet the following requisites:

- Respect the minimum distances indicated in the diagram.
- The wall on which you intend to anchor the unit must be robust and able to support its weight.
- Leave enough space around the unit to perform maintenance operations.
- Nothing must obstruct the air flow both in the top suction part (curtains, plants, furniture) and in the lower outlet part, as it could cause vibrations which might prevent the appliance from working correctly

⚠ The unit can be placed on the ground or suspended.

- ⚠ The appliance is stated as having an IPX0 protection rating, therefore it is not suitable for outdoor installation.
- ⚠ Check that there are no structures or systems (beams, pillars, hydraulic pipes, electrical cables etc.) in the part that must be drilled. Check that nothing is placed in front of the holes thus obstructing the air flow (plants and leaves, panelling, shutters, dense grates or grids, etc.)
- ⚠ The unit should not be installed in a position where the air flow is aimed directly at the people nearby;
- ⚠ Never force the air flap open;
- ⚠ The appliance must not be installed directly above another electrical appliance (TV, radio, fridge, etc.) or above a source of heat.

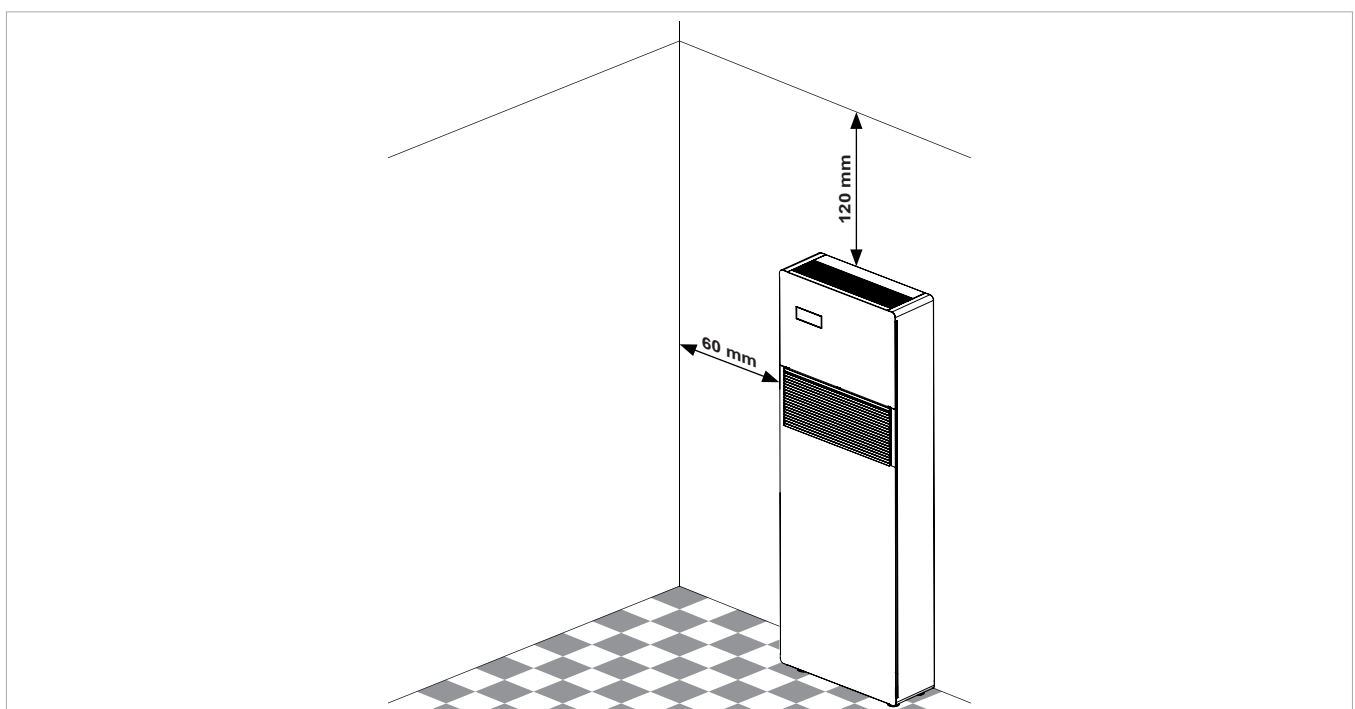



## 2.3 Assembling the unit

For the unit to work, two holes Ø162 must be placed as indicated on the template;

- ⚠ The maximum length of the holes is 1 m and there must be no bends. Use the supplied grids or grids with the same characteristics.

The holes on the wall must be drilled using suitable equipment that facilitates your work and that does not cause damage or excessive inconvenience to your customer. The best tools to make big holes on walls are special drills (called "core drills") with a high torque and whose rotation speed can be adjusted according to the diameter of the hole to make and to the material. To avoid excessive dust and debris in the room, "core drills" can be combined with suction systems consisting of a vacuum connected to a suction cup placed next to the perforation tip, for example.

To make the holes, proceed as follows:

- Place the drilling template provided against the wall respecting the minimum distances: from the ceiling, from the floor and from the side walls, indicated on the template itself, which can be held in the correct position by using some tape.
- Carefully mark the centre of each hole with a small drill or a punch before actual drilling.
- Using the core drill, make two holes for inlet and outlet air.

- ⚠ The holes must be drilled slightly downwards to prevent water from entering.

The majority of the removed material is expelled outwards, so please be careful that it doesn't hit people or objects. In order to avoid breaking the outer plaster, be careful while drilling the final part of the hole and ease the pressure on the core drill.

Drill the 6 holes for the bracket as indicated on the template.

The appliance weighs more on the right, so make sure to secure it properly on this side. The holes must have an 8 mm diameter to accommodate the 6 supplied plugs.

A thorough examination of the characteristics and consistency of the wall must always be carried out to determine the number of fixing points to be made and to choose specific plugs in particular conditions. In the case of installation on a plasterboard or on walls with low density, place a bracket, if necessary on the outside, that can support the appliance safely.

- ⚠ The manufacturer cannot be held responsible for any underestimation of the structural consistency of the anchoring carried out by the installer. We, therefore, encourage you to pay the utmost attention to this operation as, if performed badly, it could cause serious damage to people and objects.

- ⚠ Drill a hole in the position indicated on the template for those heat-pump appliances without a condensation drain built in the wall to allow for draining of condensation.

- ⚠ A hole is also indicated on the template to secure the appliance on the wall with an anti-lifting bracket, which is already on the appliance.

<b>A</b>	Holes for M8 plugs
<b>B</b>	Electrical connection area
<b>C</b>	Ø162 mm holes for air channelling
<b>D</b>	Ø16 mm condensation drain
<b>E</b>	Anti-lifting bracket hole

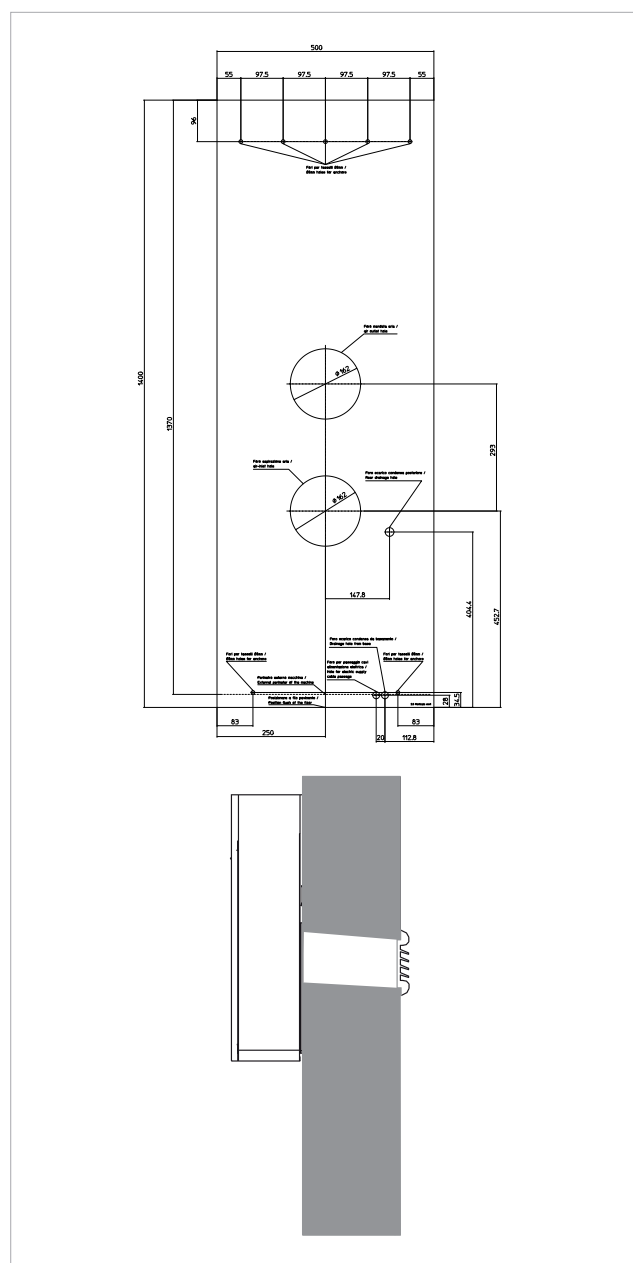

## 2.4 Condensation drain preparation

For heat pump appliances, a condensation drain pipe (internal Ø16 mm, not supplied) must connect the unit to the pipe on the rear of the appliance.

A solenoid valve will start the flow of the condensation from the internal collection tray when the maximum level has been reached. For cooling only appliances, this pipe must be connected if the appliance is intended for use with low external temperatures (below 23°C). Drainage occurs by gravity. For this reason, it is essential for the discharge pipe to have at least a 3% minimum slope in every point. The pipe to be used can be rigid or flexible with a minimum inner diameter of 16 mm. If the line flows into a sewer system, it is necessary to add a siphon before placing the pipe into the main drain. This siphon must be placed at least 300 mm under the mouth of the appliance.

- ⚠ If the line flows into a container (e.g. a tank), do not close the container hermetically and avoid immersing the draining pipe into the water.
- ⚠ The hole for the condensation pipe must always slope towards the outside.
- ⚠ The exact position in which to place the pipe mouth is indicated on the template.

- ⚠ Check that the expelled water does not cause any damage or problems to people or objects. During winter, this water may create sheets of ice outside.
- ⚠ When connecting the condensation drain, be careful not to squeeze the rubber duct.
- ⚠ It is possible to empty the collection tray using the safety drain at the base of the appliance if necessary.
- ⚠ Use plastic drainage pipes.
- ⚠ Avoid pipes made of metallic material.
- ⚠ Condensate drainage pipes must be insulated for both indoor and outdoor sections of the house to avoid condensation on the surface and/or freezing problems.

### 1 Safety drain to empty tray

### 2 Condensation drain duct

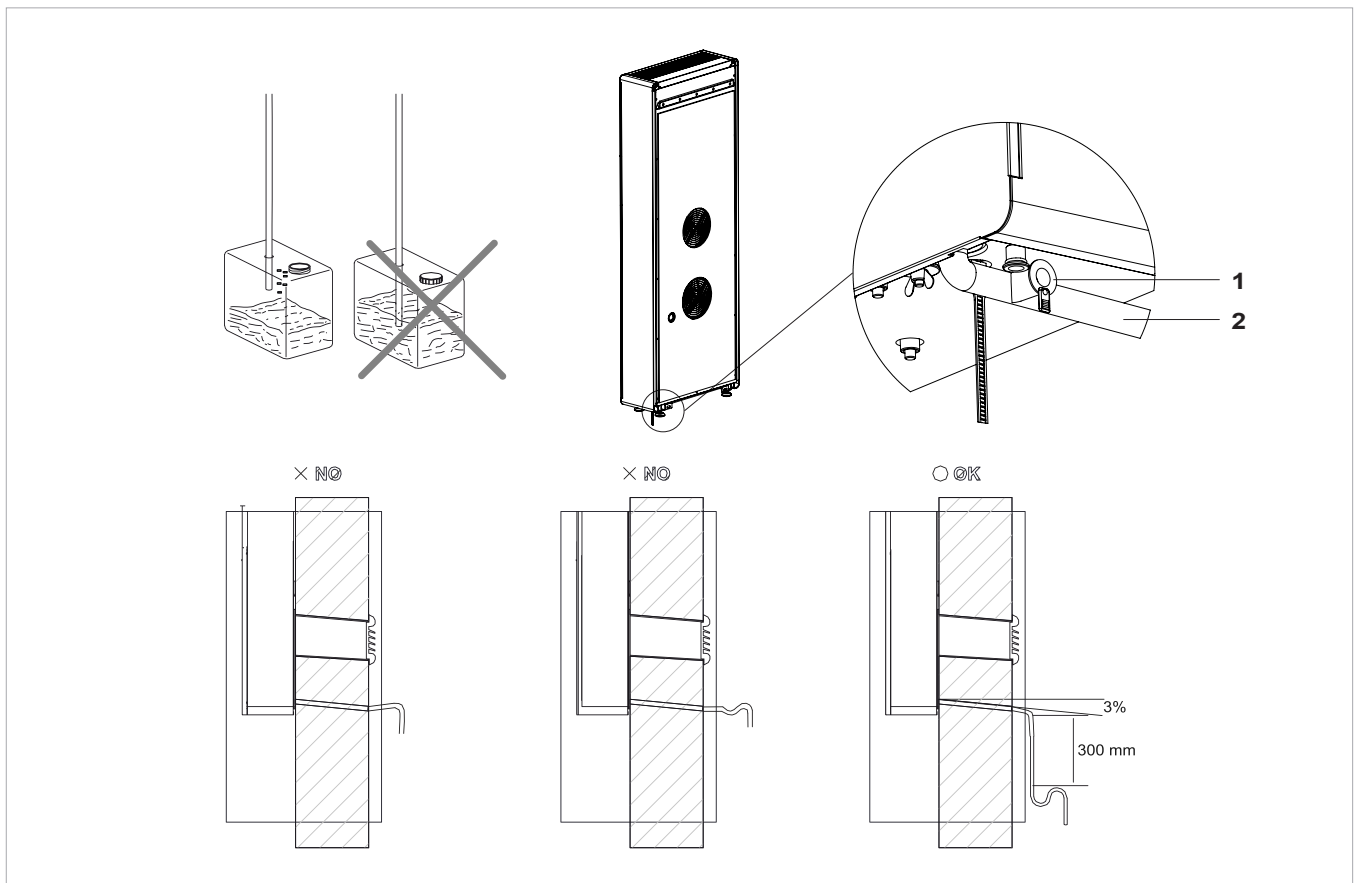

### Insulation of the internal condensation drain pipe

NB: when laying the condensation drain pipe towards the outside, the internal pipe supplied with the appliance should be lined with anti-condensation insulating material with an internal diameter of 10 mm (see point 2 in the diagram).

The insulating material should be fitted up to the mouth of the external condensation drain pipe fixed in the wall.

<b>1</b>	Wall section
<b>2</b>	Insulation
<b>3</b>	Emergency drain

<b>4</b>	External condensation drain pipe
<b>A</b>	2.0 Conditioner
<b>B</b>	Ventilation hole

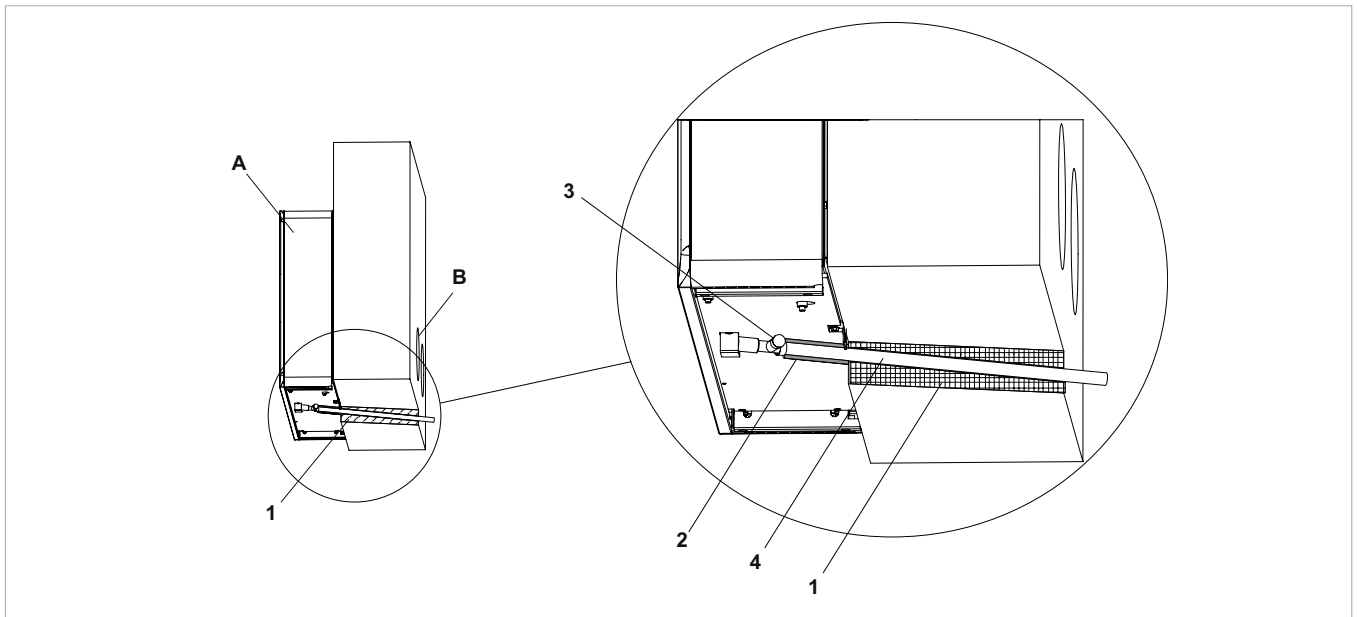

### 2.5 Removing the compressor block

To prevent the compressor and the pipes from moving during transportation and installation, a bracket is used to block the compressor. This bracket must be removed before starting up the compressor:

in the lower right part of the appliance, by the red label, there are two wing nuts that must be completely unscrewed to free the compressor.

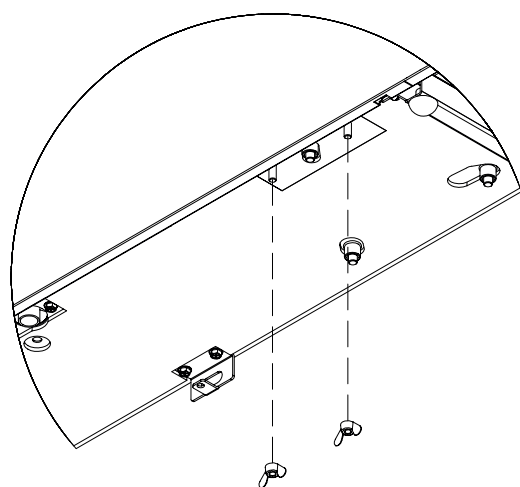

- I** ATTENZIONE: RIMUOVERE IL BLOCCO COMPRESSORE PRIMA DI AVVIARE LA MACCHINA (VEDERE MANUALE INSTALLAZIONE)
- EN** WARNING: REMOVE COMPRESSOR LOCK BEFORE START THE UNIT (SEE USER MANUAL)
- D** ACHTUNG: ENTFERNEN SIE DIE BEIDEN SCHRAUBEN, BEVOR SIE DEN KOMPRESSOR STARTEN (SIEHE INSTALLATIONSANLEITUNG)
- F** ATTENTION: ENLEVEZ LE BLOC DU COMPRESSEUR AVANT DE COMMENCER LA MACHINE (VOIR LE MANUEL D'INSTALLATION)
- ES** ADVERTENCIA: RETIRE EL BLOQUE DEL COMPRESOR ANTES DE COMENZAR LA MÁQUINA (VEA EL MANUAL DE INSTALACIÓN)
- P** CUIDADO: RETIRE O BLOCO DO COMPRESSOR ANTES DE COMEÇAR A MÁQUINA (VER MANUAL DE INSTALAÇÃO)
- NL** LET OP: VERWIJDER DE COMPRESSOR-BLOKKERING VOORDAT U HET TOESTEL INSCHAKELT (ZIE INSTALLATIEHANDLEIDING)

## 2.6 Assembling air ducts and external shutters

Once the holes have been made, place the supplied plastic sheets inside them.

Roll up the sheet and insert it in the hole, checking that the A junction line is aiming upwards. Use a cutter to remove any excess pipe.

To place the external grids, proceed as follows:

- connect the chains to the ends of the springs;
- fold the external shutters;
- insert your arm in the hole to push the shutter outside while holding the ends of the chains with the other hand to prevent them from falling down;
- open the shutter inside the hole;
- rotate the shutter to bring the flap in the vertical C position and check that the closing mechanism works;
- pull the chains by tensioning the springs;
- use a bolt cutter to remove any excess chain.
- anchor the hook of the chain to wall B.

- ⚠ Use only the supplied grids or grids with the same characteristics.
- ⚠ The shutters must be positioned with the flap in vertical.
- ⚠ The shutters are different. Should be distinguished from that position on the recovery from the one place on the delivery, according to the opening direction of the fins.

Once installation of the grilles is complete check their opening (towards the inside of the duct for the air inlet grid "IN" and towards the outside of the duct for the air outlet grid "OUT"). Remember that the grilles open when the external air flow is activated, to allow the cooling and heating functions to be operated. The conditioner must be activated for cooling or heating in order to test them.

<b>A</b>	Junction line
<b>B</b>	Hook

<b>C</b>	Flap in ventilation position
----------	------------------------------

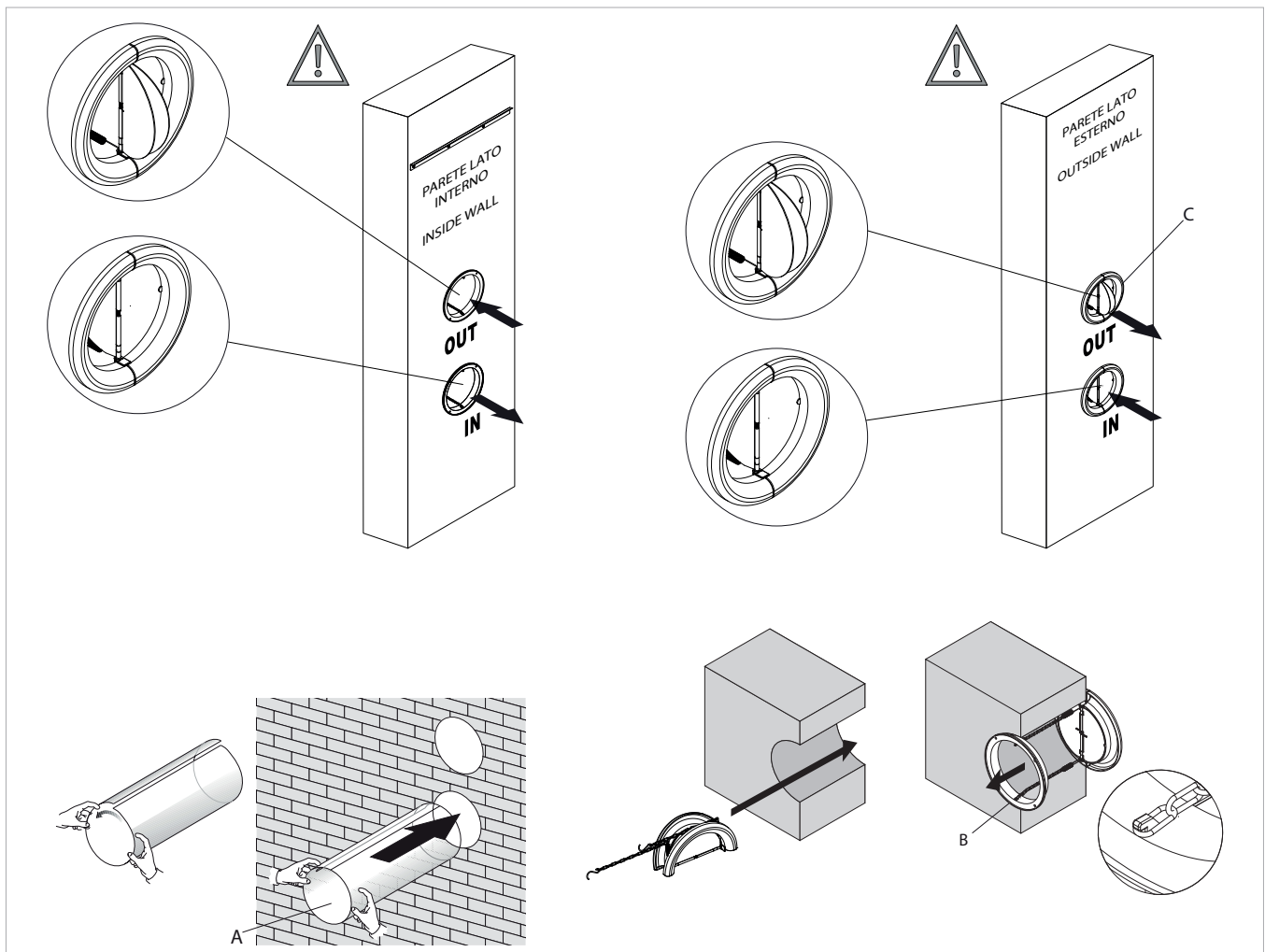

## 2.7 Mounting the appliance on the bracket

After checking that the bracket is anchored to the wall and that all necessary electrical connections and condensation drain preparations have been made, you can mount the conditioner. Lift it by the sides of the bottom base until the bracket fits on all of the right spots on the appliance. In order to ease the operation, slightly tilt the appliance towards you.

Direct electrical connections (disconnecting the power supply cable) and the anchoring of the condensation drain must be carried out after having spaced the appliance from the wall using a wooden wedge or any other similar

object.

Once the work is done, check that there are no openings on the back of the appliance, especially where the air ducts are connected. To improve installation safety, the machine can be secured to the wall with a dedicated anti-lifting bracket

which is located on the rear part of the machine. The drilling position is indicated on the installation template.

<b>1</b>	Bracket
<b>2</b>	Bracket anchoring points

<b>3</b>	Anti-lifting bracket
----------	----------------------

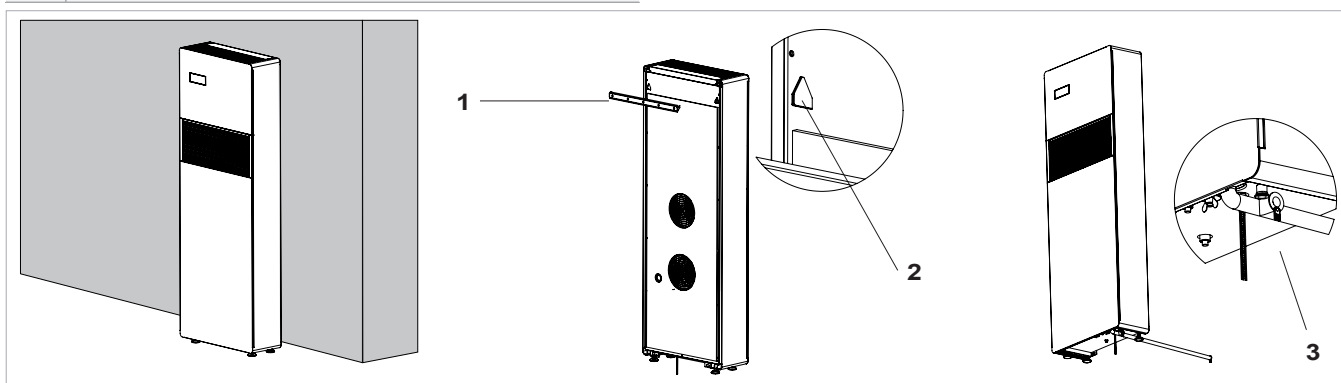

## 2.8 Electrical connection

The appliance is equipped with a power cord and plug (Y-type connection, the cord can only be replaced by the manufacturer, the assistance centre or a qualified installer). If using a socket near the appliance, simply insert the plug.

- ⚠ Before connecting the conditioner check that:
  - The power supply voltage and frequency values comply with the data plate of the appliance.
  - The power supply line has a suitable earth connection and that it is sized for the maximum absorption of the conditioner (minimum cable section equal to 1.5 mm<sup>2</sup>).
  - Power is only supplied using a suitable socket through the supplied plug.

- ⚠ If the supply cable is replaced, this must be done exclusively by the technical assistance service or by authorised personnel and in compliance with current national regulations.

- ⚠ The appliance must be connected to 230V/50 Hz mains via an omnipolar switch with a contact opening distance of minimum 3 mm, or using a device enabling the complete disconnection of the appliance in overvoltage III category conditions.

It is possible to carry out the electrical connection using a cable inside of the wall as indicated in the installation template (recommended for installations in the upper part of the wall).

Please check that the power supply is provided with suitable protections against overloads and/or short-circuits (using a 10 Amp Time delay fuse or other equivalent devices is recommended).

To prevent any risk of electrocution, always disconnect the main circuit breaker before making electric connections or performing any maintenance on the units.

To carry out direct connections and substitute the power cord using the cable in the wall, proceed as follows:

- Remove the upper grill.
- Remove the two plastic side panels, by lifting them upwards.
- Undo the front panel fixing screws.
- Remove the front panel.
- Disconnect the power cord by unscrewing the 3 screws from the terminal block.
- Connect the wall cable, checking that the power supply line has a suitable earth connection and that it is sized for the maximum absorption of the conditioner (minimum cable section equal to 1.5 mm<sup>2</sup>).

### CP occupancy contact input connection

When the CP contact opens (very low voltage, connected to a free non-live contact) the appliance is put in stand-by and CP appears on the display.

Using this contact, it is possible to connect an external device that inhibits the functioning of the appliance

such as: open window contact, on/off remote, infrared presence sensors, enabling badge, etc.

We recommend using a double insulation cable.

<b>A</b>	230V/50 Hz Electrical power supply terminal block
<b>B</b>	CP contact presence
<b>1</b>	Air outlet grill
<b>2</b>	Air intake grill

<b>3</b>	Front panel
<b>4</b>	Fixing screws
<b>5</b>	Front closing panel

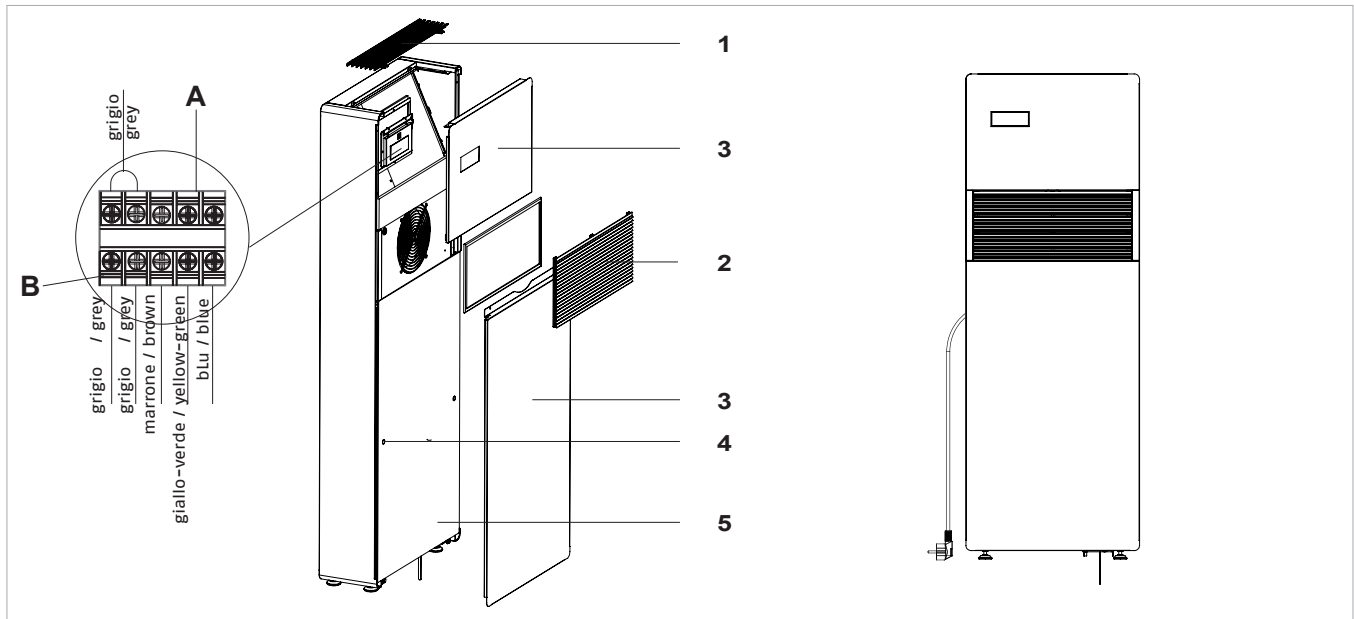

### 2.9 Setting cool only or heat only modes

It is possible to deactivate the heating or the cooling modes following a simple procedure.

Keep the A key on the touch-screen display pressed for 5 seconds until HC (heating and cooling) appears on the display.

Press the A key for 1 second to switch to the Co (cooling

only) mode.

Press the A key again to switch back to Ho (heating only) mode.

Wait for 3 seconds without touching anything to memorise the setting.

### 2.10 Brightness regulation

The display brightness sensor can be disabled (leaving the maximum brightness at all times) by pressing and holding

the night button (🌙) for 10 seconds. "ds" (disabled) or "En" (enabled) will appear on the display.

### 2.11 Touch-screen display key lock

The key lock is activated by keeping the Timer (🕒) symbol on the touch-screen display pressed for three seconds.

The user cannot perform any actions.

The stand-by symbol flashes every second.

To deactivate the lock, keep the Timer symbol pressed for three seconds once again.

The lock remains active also for the next operations performed via remote control and in the event of a power failure.

### 2.12 Hotel function

Press and hold the air exchange key (🌀) for 10 seconds to enable the function ("En" displayed); the dehumidification and Auto functions are disabled (leaving active only ventilation, heating and cooling) and the settable set range

is reduced from 22 to 28 in cooling mode and from 16 to 24 in heating mode).

## 2.13 Detecting possible faults

If the conditioner blocks because of an alarm (see following table), please communicate to the assistance centre the

code on the display to facilitate interventions.

Display indications	Cause
E1	Faulty room temperature RT probe
E2	Faulty evaporative battery IPT probe
E3	Faulty outdoor air temperature OT probe
E4	Faulty conditioner battery OPT probe
E5	Faulty indoor air fan motor
E6	Faulty outdoor air fan
E7	Lack of communication with the display
E8	Compressor discharge probe failure (only for DC Inverter models)

### Open CP contact

If the presence contact is not closed, the appliance will not start and the **CP** alarm appears on the display.

### Evacuation of condensate water in the event of an emergency

Should any anomaly occur in the condensation water system, the maximum level float blocks the conditioner and the **OF** code appears on the display.

During cooling and dehumidification, electronics keeps the water distribution system active with the battery - together with the fan - to disperse excess water in the container. If the problem persists, please contact the assistance

service.

During heating, condensation should drain freely through the specific pipe. In the event of an alarm, check that the condensation pipe is not bent or obstructed, thus preventing the water from flowing out.

### Use of the appliance

⚠ Objects or structural obstacles (furniture, curtains, plants, leaves, blinds, etc.) must not obstruct the normal air flow both from the internal and from the external grids.

⚠ Do not lean against, or worse sit on, the body of the conditioner, this would damage the appliance.

⚠ In the event of water leaks, turn off the appliance and disconnect the electric power supply. Call the nearest service centre.

⚠ During heating mode, the conditioner eliminates periodically any ice formed on the external battery. In such situation, the machine keeps on working, but it does not dispense warm air to the room. This phase can last from 3 up to maximum 10 minutes.

⚠ The appliance must not be installed in rooms where explosive gases develop or where there are humidity and temperature conditions that exceed the maximum levels reported on the installation manual.

⚠ Clean the air filter regularly as described in the specific paragraph.

### Operations after installation

Before leaving the site, the packaging should be gathered up and all traces of dirt that have deposited on the unit during assembly should be eliminated with a damp cloth. These operations, which are not strictly necessary, in any case allow for a more professional appearance of the installation in the eyes of the user.

To avoid unnecessary calls by the user, before leaving the site it is also a good idea to:

- outline the contents of the manual,
- show them how to clean the filter,
- explain when and how they should contact Customer Service.

## MAINTENANCE

### 3.1 Periodic Maintenance

The air conditioner you have bought has been designed to keep maintenance operations to a minimum, in fact, they

only include the following cleaning operations:

#### External cleaning

- ⚠ Disconnect the unit from the power supply before each cleaning and maintenance intervention by setting the main power supply switch to off.
- ⚠ Wait for the components to cool down in order to avoid any burns.
- ⚠ Pay attention to the sharp edges.
- ⚠ Do not use abrasive sponges or abrasive or corrosive detergents as you might damage the painted surfaces.

When necessary, clean the external surfaces with a soft damp cloth.

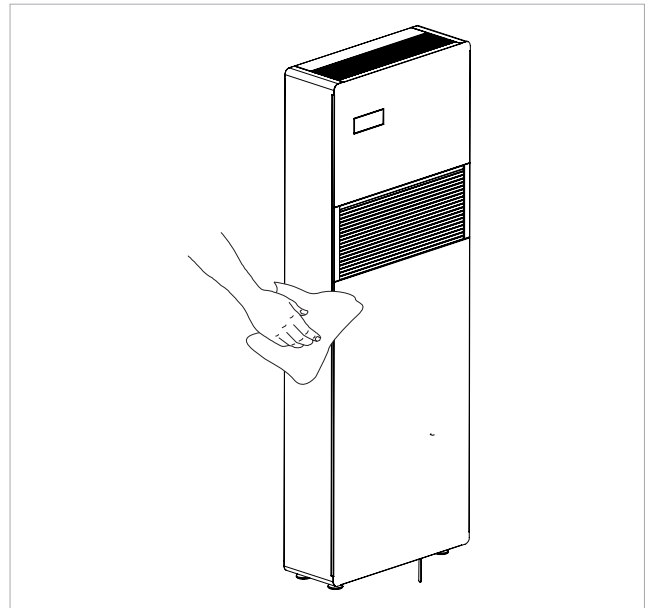

#### Cleaning the filters

The air conditioner you have bought has been designed to keep maintenance operations to a minimum, in fact, they only include the following cleaning operations:

Clean the air filter after a period of continuous use and according to the concentration of impurities in the air, or when you wish to start-up the appliance after a period of inactivity.

NB: before performing any operation, take care with the hot and/or sharp surfaces of the metal.

The filter is located in the top part of the appliance.

To extract the filter:

- open the grille and carry out operations 1, 2, 3, then remove it from its housing;
- extract the filter by lifting it;
- remove the dust from the filter with a vacuum cleaner or by washing it in running water without using detergents or solvents and leave to dry;
- put the filters back on top of the coils, taking care to position them correctly;
- put the grille back in reverse order.

⚠ After filter cleaning, check if the panel is properly mounted.

⊘ It is forbidden to use the device without its mesh filter.

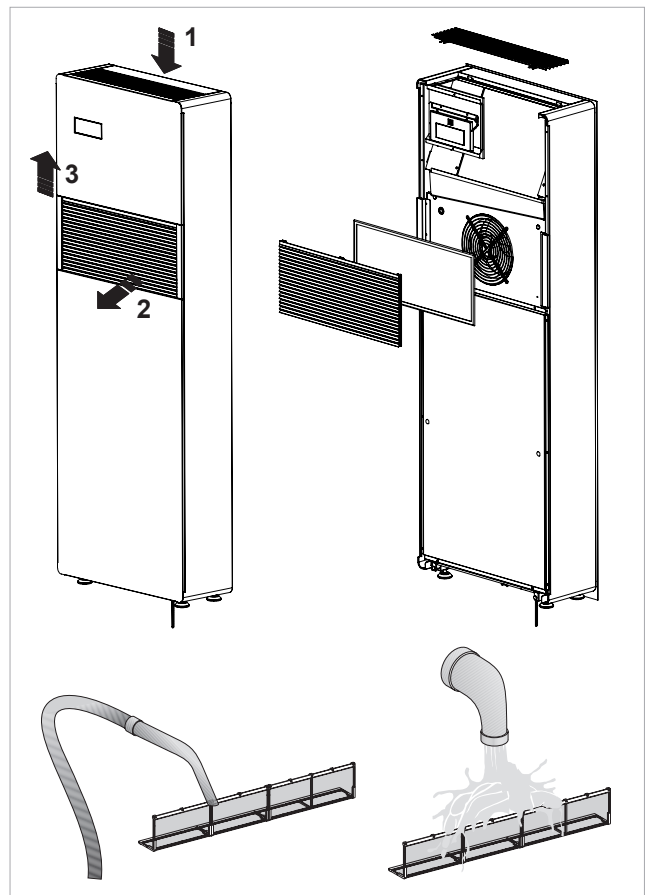



### 3.2 Troubleshooting

In the even of a malfunction, please refer to the following table. If, after performing the suggested checks, the problem is not solved, please contact the authorised technical assistance.

Fault	Possible causes	Solution
The appliance doesn't switch on	No power supply	Check there is power supply (by turning a light on, for example). Check that the thermal-magnetic circuit breaker used exclusively to protect the appliance has not been tripped (if it has, reset it). If the problem repeats immediately, please call the Service Centre and avoid trying to make the appliance work.
	Remote control batteries have run out	Check that the appliance can be turned on using the touch-screen display and substitute the batteries.
The appliance does not cool/heat adequately.	The temperature set is too high or too low.	Check and, if necessary, adjust the temperature setting on the remote control
	The air filter is clogged	Check the air filter and clean it if necessary
	Check that there are no other obstacles to the air flow both inside and outside.	Remove anything that might block the air flow.
	The heating and cooling load has increased (for example, a door or a window has been left open or an appliance has been installed in the room which generates a lot of heat).	Try to reduce the heating and cooling load of the room following instructions below: Cover large windows exposed to sunlight with curtains or with external maskings (blinds, porches, reflecting films, etc.); The air conditioned room must remain closed for as long as possible; Avoid turning on halogen lamps or other high energy consumption appliances such as small ovens, steam irons, hot plates etc.).

### Display alarms

An alarm code appears on the display in the event of faults. Some of the functions, however, remain active (see FUNCTIONING column).

Alarm	Cause	Operation
E1	Faulty room temperature RT sensor	It is still possible to activate Cooling, Dehumidification and Heating modes. It only monitors the antifreeze function of the internal coil.
E2	Faulty internal coil IPT sensor	None of the modes can be activated.
E3	Faulty outside temperature OT sensor	None of the modes can be activated.
E4	Faulty external coil OPT sensor	It is still possible to activate Cooling, Dehumidification and Heating modes. Defrosting is performed at fixed times.
E5	Faulty internal fan motor	None of the modes can be activated.
E6	Faulty external fan motor	None of the modes can be activated.
E7	Lack of communication with the display *	None of the modes can be activated.
E8	Compressor discharge probe failure *	None of the modes can be activated.
CP	Open CP contact	The appliance only works if the contact is closed. Check that the clamps are connected.
OF	Maximum level float intervention	During cooling and dehumidification, electronics keeps the water distribution system active with the battery - together with the fan - to disperse excess water in the container. During heating, condensation should drain freely through the specific pipe. In the event of an alarm, check that the condensation pipe is not bent or obstructed, thus preventing the water from flowing out.

\* for DC Inverter models: lack of communication between the main, power, driver or display boards

The only way to solve the problem is to disconnect and reconnect the appliance. If the alarm still appears, please contact the authorised technical assistance.

### 3.3 Technical specifications

Please read data plate to obtain the technical data listed below.

- Power supply voltage
- Maximum absorbed power
- Maximum absorbed current
- Amount of refrigerant gas
- Casing protection rating

	U.M.	10 HP DC Inverter	12 HP DC Inverter
<b>Technical specifications</b>			
Cooling power (1)	kW	2.04	2.35
Power in max cooling mod. Dual Power	kW	2.60	3.11
Power in min cooling mod. Dual Power	kW	0.81	0.92
Heating power (2)	kW	2.10	2.36
Heating power (3)	kW	0.98	1.11
Additional power electrical resistance	kW	/	/
Power in max heating mod. Dual Power	kW	2.64	3.05
Power in min heating mod. Dual Power	kW	0.68	0.79
Power absorbed when cooling (1)	W	750	855
Power absorbed when heating (2)	W	675	750
Dehumidification capacity	L/h	0.8	0.9
Power supply voltage	V-F-Hz	230-1-50	230-1-50
EER	W/W	2.72	2.75
COP	W/W	3.10	3.15
Energy efficiency class when cooling		A	A
Energy efficiency class when heating		A	A
Internal-external ventilation speed	No.	3	3
Internal/external air flow at max speed	m³/h	380/460	400/480
Internal/external air flow at medium speed	m³/h	310/380	320/390
Internal/external air flow at min speed	m³/h	260/330	270/340
Dimensions (WxHxD)	mm	500x1398x185	500x1398x185
Weight	kg	57	57
Sound pressure level (min-max) (4)	dB(A)	26/39	27/41
Unit sound power level inside (min-max) (5)	dB(A)	44/57	45/58
Wall holes diameter	mm	162	162
Wall holes distance	mm	293	293
Refrigerant gas		R410A	R410A

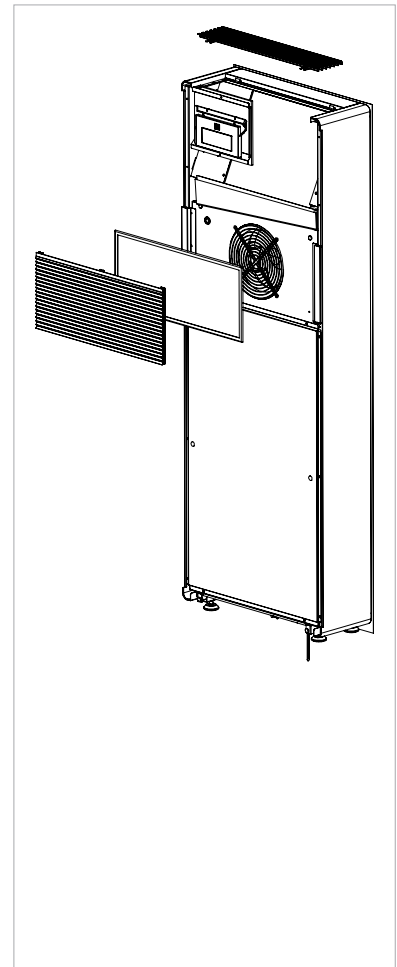

\* with Dual Power function activated during heating

<b>Reference conditions</b>			
		Room T	External T
(1)	Cooling mode tests (EN 14511)	DB 27°C - WB 19°C	DB 35°C - WB 24°C
(2)	Heating mode tests (EN 14511)	DB 20°C - WB 15°C	DB 7°C - WB 6°C
(3)	Heating mode tests	DB 20°C - WB 15°C	DB -7°C - WB -8°C
(4)	Internal side sound pressure measured in semi-anechoic chamber at a distance of 2 m.		
(5)	Internal side sound pressure measured in accordance with regulation EN 12012		

<b>Operating limits</b>		
	Internal ambient temp.	External ambient temp.
Maximum operating temperature in cooling mode	DB 32°C	DB 43°C
Minimum operating temperature in cooling mode	DB 18°C	DB -5°C
Maximum operating temperatures in heating mode	DB 25°C	DB 18°C
Minimum operating temperatures in heating mode	DB 5°C	DB -10°C

### RED Compliance Statement

#### Compliance with 2014/53/EU Radio Equipment Directive (RED).

In accordance with Article 10.8(a) and 10.8(b) of the RED, the following table provides information on the frequency

bands used and the maximum RF transmit power of the product for sale in the EU:

Frequency range (MHz)	Max. Transmit Power (dBm)
2400-2472	< 20

Hereby, the company declares that the device is in compliance with Directive 2014/53/EU.

This equipment should be installed and operated with a minimum distance of 20 centimeters between the radiator and your body.

 For declarations of conformity, certificates and other certification details please consult the website.

### Safety

This equipment is designed with the utmost care for the safety of those who install and use it. However, special attention must be paid to the dangers of electric shock and static electricity when working with electrical equipment.

All guidelines of this and of the computer manufacture must therefore be allowed at all times to ensure the safe use of the equipment.



**innova**

INNOVA s.r.l.  
Via I Maggio 8 - 38089 STORO (TN) - ITALY  
tel. +39.0465.670104 fax +39.0465.674965  
[info@innovaenergie.com](mailto:info@innovaenergie.com)

N420036A - Rev. 07